

XRW

FOR FIX INSTALLATION
Product Series

- XRW Transparent LED Screen is aimed at fix installation in shopping mall, airport, hotel and car showroom etc.

Front



Back



● Features & Advantages



High transparency



Modular design



Easy installation and debug



Easy transportation with light weight



High brightness



Easy maintenance and update



Noise-free power supply



Stable performance

● Quick and Easy Installation Design

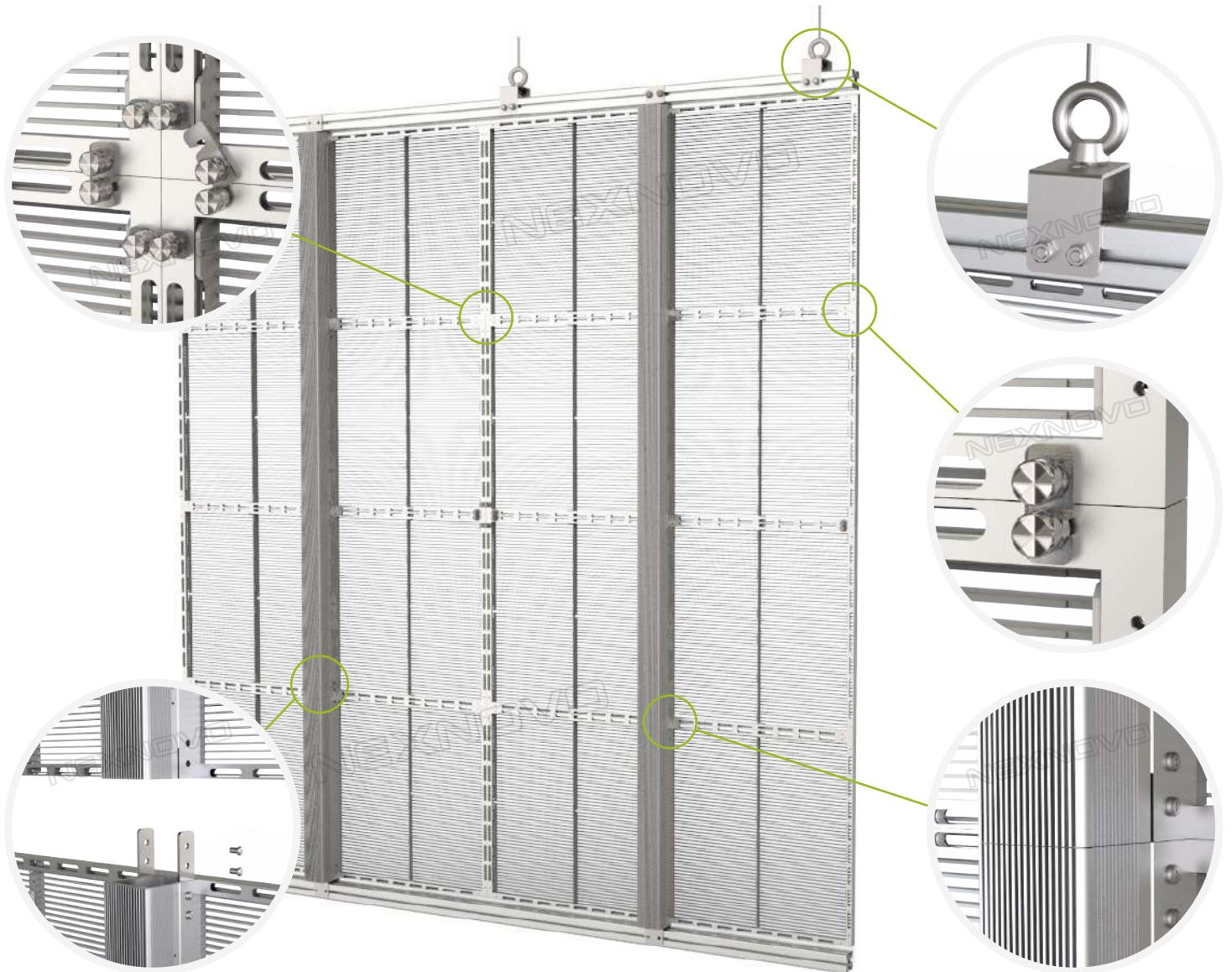

● Sizes

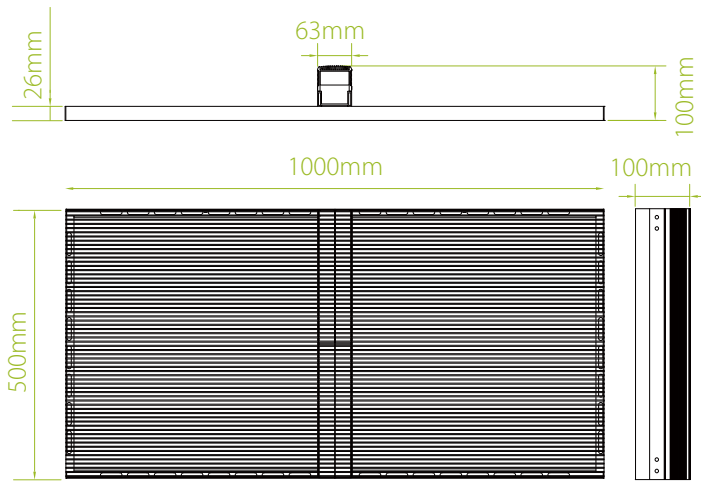

XRW3 Size

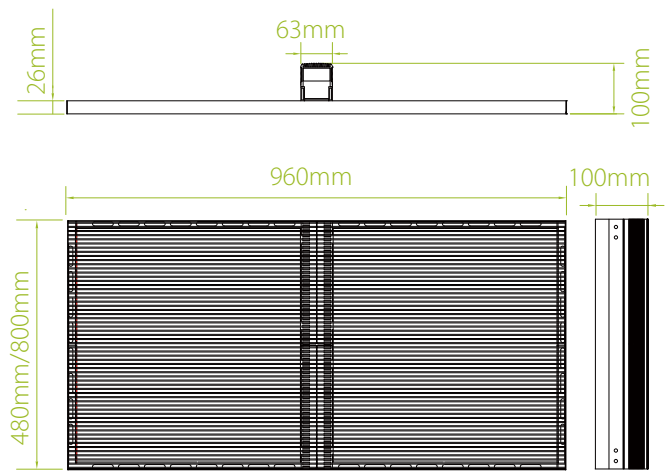

XRW8 Size

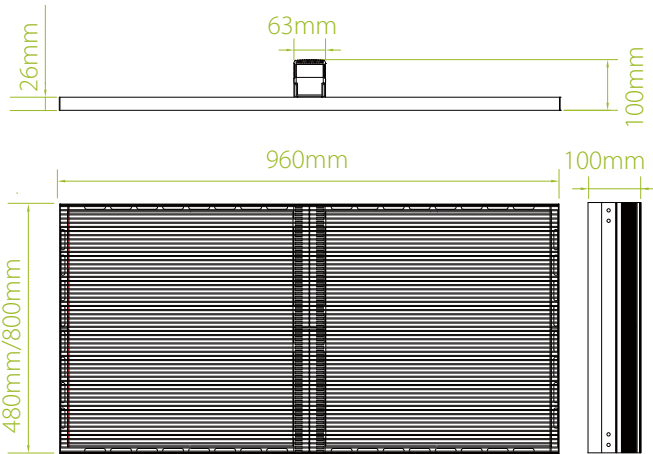

XRW10 Size

● Specifications

Type	XRW3	XRW8	XRW10
Pixel Pitch(mm)	3.9×7.8	7.5×8	10×10
LED Model	SMD 1921	SMD 1921	SMD 1921
Brightness(cd/m ²)	5500~6000	5500~6000	5500~6000
Transparency	>75%	>75%	>80%
Display Size(mm)	1000×500	960×480 960×800	960×480 960×800
Display Resolution	256×64	128×60 128×100	96×48 96×80
Resolution(dot/m ²)	32873	16666	10000
Max.Power(w/m ²)	800	868	868
Avg.Power(w/m ²)	240	280	280
Ingress Protection	IP20	IP20	IP20
Refresh Rate(HZ)	≥1920	≥1920	≥1920
Weight(kg/m ²)	7	6.2 10	6 9.5
Working Temp(℃)	-10~40	-10~40	-10~40



SCREEN LINE S.r.l.

38060 Besenello (TN) Via Nazionale, 1/n - 1/u | T.+39 0464 830003 | F. +39 0464 830500

info@screenline.it | screenline.it