

### ITALIANO

MORSETTI	ALIMENTAZIONE	MOTORE (EUR)	MOTORE (US)
L	FASE (L)		
N	NEUTRO (N)	BLU	BIANCO
W	TERRA (W)	GIALLO/VERDE	VERDE
1		NERO O MARRONE	NERO O ROSSO
2		NERO O MARRONE	NERO O ROSSO

- Scollegare l'alimentazione di rete prima dell'intervento.
- Dopo l'installazione non si dovrà esercitare alcuna trazione sulle morsettiere.
- Collegare i fili di terra prima della fase e del neutro.

### ENGLISH

TERMINALS	POWER SUPPLY	MOTOR (EUR)	MOTOR (US)
L	PHASE (L)		
N	NEUTRAL (N)	BLUE	WHITE
W	EARTH (W)	YELLOW/GREEN	GREEN
1		BLACK OR BROWN	BLACK OR RED
2		BLACK OR BROWN	BLACK OR RED

- Disconnect the main supply before carrying out any work.
- Ensure that no forces act on terminals after installation.
- Connect the earth wires before phase and neutral.

### FRANCAIS

BORNES	ALIMENTATION	MOTEUR (EUR)	MOTEUR (US)
L	PHASE (L)		
N	NEUTRE (N)	BLEU	BLANC
W	TERRE (W)	JAUNE/VERT	VERT
1		NOIR OU MARRON	NOIR OU ROUGE
2		NOIR OU MARRON	NOIR OU ROUGE

- coupez l'alimentation secteur avant l'intervention.
- après l'installation, aucune traction ne doit s'exercer sur les borniers.
- branchez les fils de terre avant la phase et le neutre.

### DEUTSCH

KLEMMEN	NETZ	ANTRIEB (EUR)	ANTRIEB (US)
L	PHASE (L)		
N	NULLPUNKT (N)	BLAU	WEISS
W	ERDUNG (W)	GELB GRÜN	GRÜN
1		BRAUN O. SCHWARZ	ROTO. SCHWARZ
2		BRAUN O. SCHWARZ	ROTO. BRAUN

- Vor Durchführung der Arbeiten Netzanschluss freischalten, und gegen unbeabsichtigtes Einschalten sichern.
- Nach der Installation darf kein Zug auf die Klemmen entstehen.
- Zuerst Schutzleiter erst dann Phase und Mittelleiter anschließen.

### ESPAÑOL

CONEXIONES	ALIMENTACION	MOTOR (EUR)	MOTOR (US)
L	FASE (L)		
N	NEUTRO (N)	AZUL	BLANCO
W	TIERRA (W)	AMARILLO/VERDE	VERDE
1		NEGRO O MARRÓN	NEGRO O ROJO
2		NEGRO O MARRÓN	NEGRO O ROJO

- Corte la alimentación de la RED antes de la intervención.
- Después de la instalación, no se debe efectuar ninguna tracción sobre los bornes de conexión.
- Conecte los cables de tierra antes de la fase y el neutro.

### عربي

المرفقات التلامس	التغذية الكهربائية	محرك (EUR)	محرك (US)
L	خط طور (L)		
N	خط بارد (N)	أزرق	أبيض
W	خط أرضي (W)	أصفر/أخضر	أخضر
1		أسود أو بني	أسود أو أحمر
2		أسود أو بني	أسود أو أحمر

- إقصّل الكهرباء (خط طور) قبل التوصيل.
- عدم سحب الأسلاك (عند نقط التوصيل) بعد التوصيل.
- يجب توصيل الخط الأرضي قبل خط طور والبارد.

### 中文

接线端	电源	电机 (欧洲)	电机 (美国)
L	相线 (L)		
N	中线 (N)	蓝色	白色
W	地线 (W)	黄色/绿色	绿色
1		黑色或褐色	黑色或红色
2		黑色或褐色	黑色或红色

- 操作前，先切断该区段的电源。
- 安装后，不可再拉牵接线柱。
- 地线须在相线和中线之前插上。

### РУССКИЙ

ЗАЖИМЫ	СЕТЬ	ПРИВОД (Европа)	ПРИВОД (США)
L	ФАЗА (L)		
N	НЕЙТРАЛЬ (N)	СИНИЙ	БЕЛЫЙ
W	ЗЕМЛЯ (W)	ЖЕЛТО-ЗЕЛЕНЫЙ	ЗЕЛЕНЫЙ
1		ЧЕРН. ИЛИ КОРИЧН.	ЧЕРН. ИЛИ КОРИЧН.
2		ЧЕРН. ИЛИ КОРИЧН.	ЧЕРН. ИЛИ КОРИЧН.

- Работы выполнять только при отключенной сети.
- После монтажа провода не должны действовать на Зажимы втяг.
- Вначале подсоединять провод Заземления, Затем

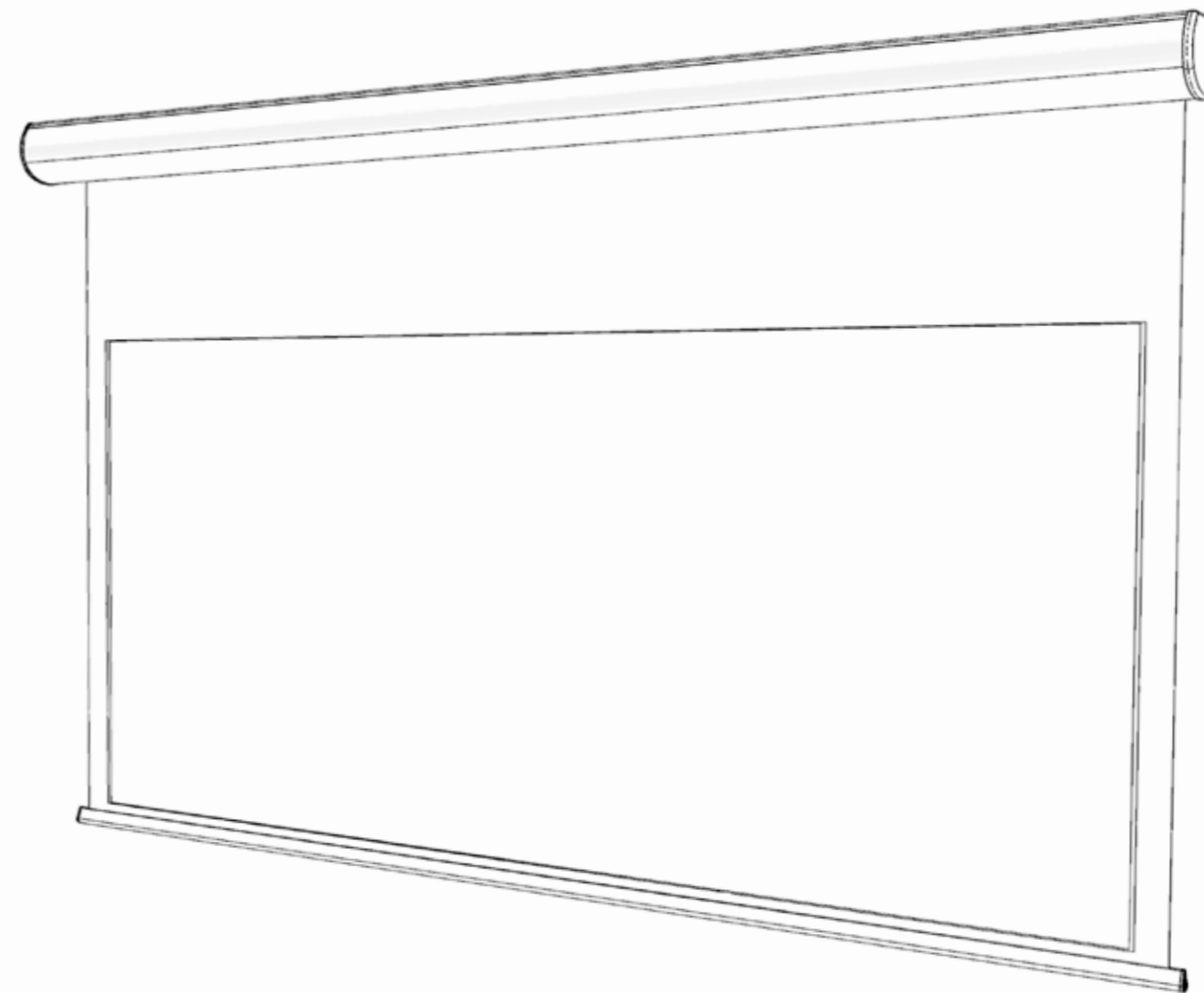

# JAGO

# JAGO TENSIONATO

IS2013\_JAG001

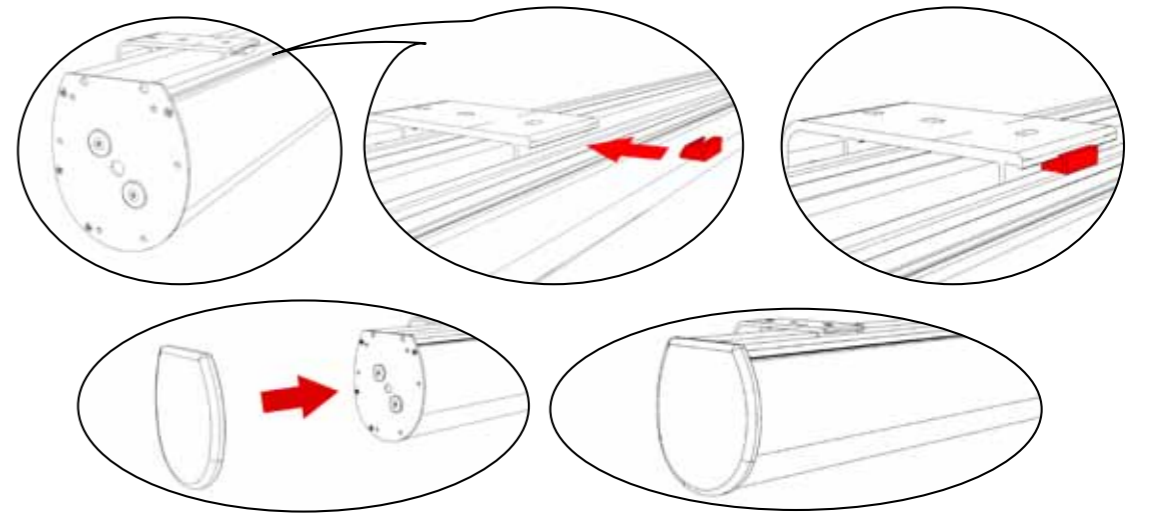
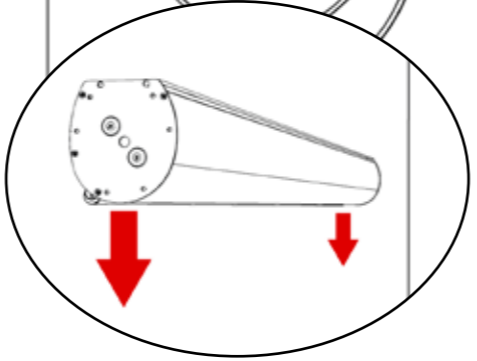
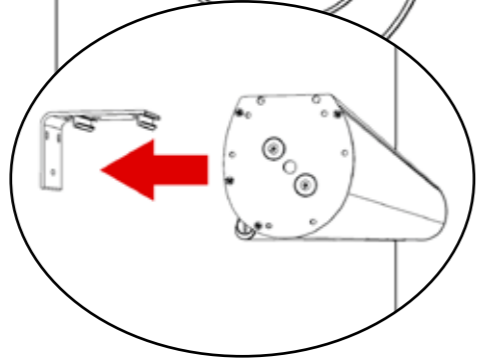
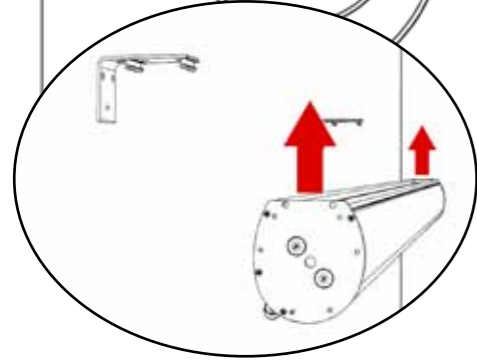
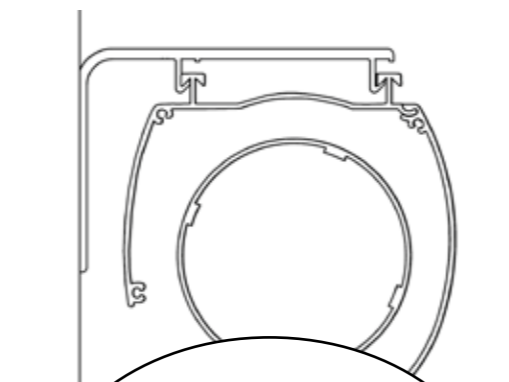
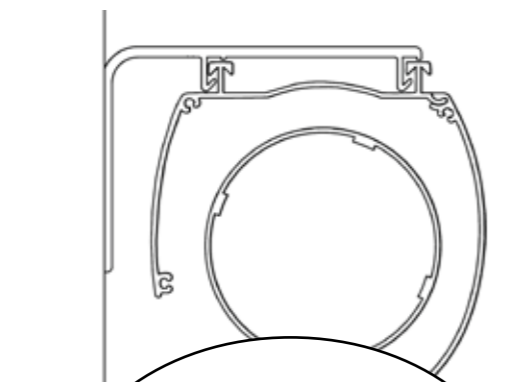
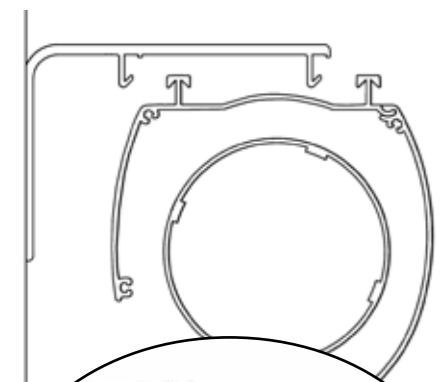
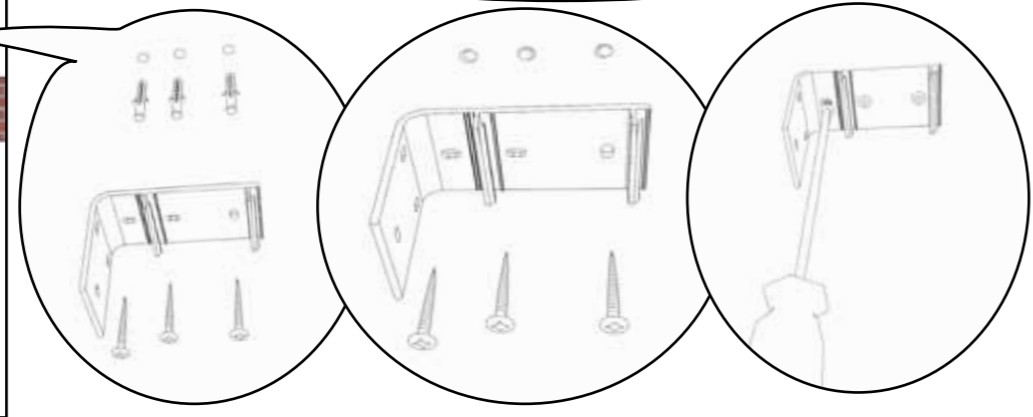
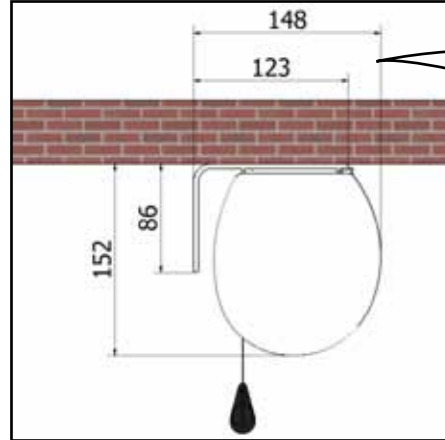
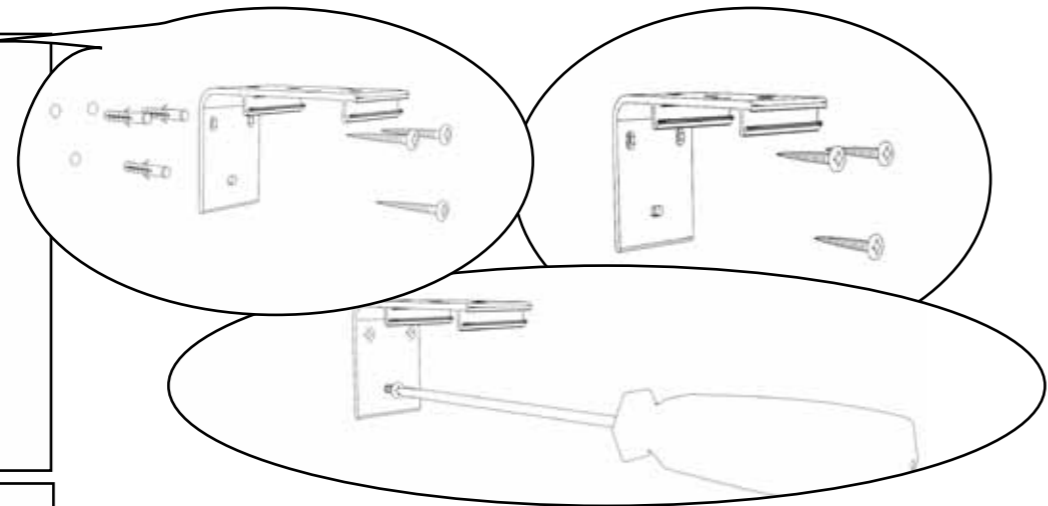
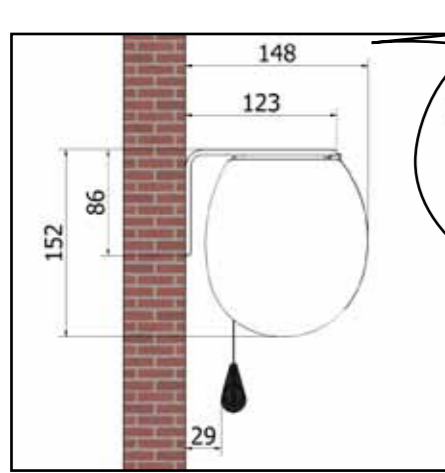
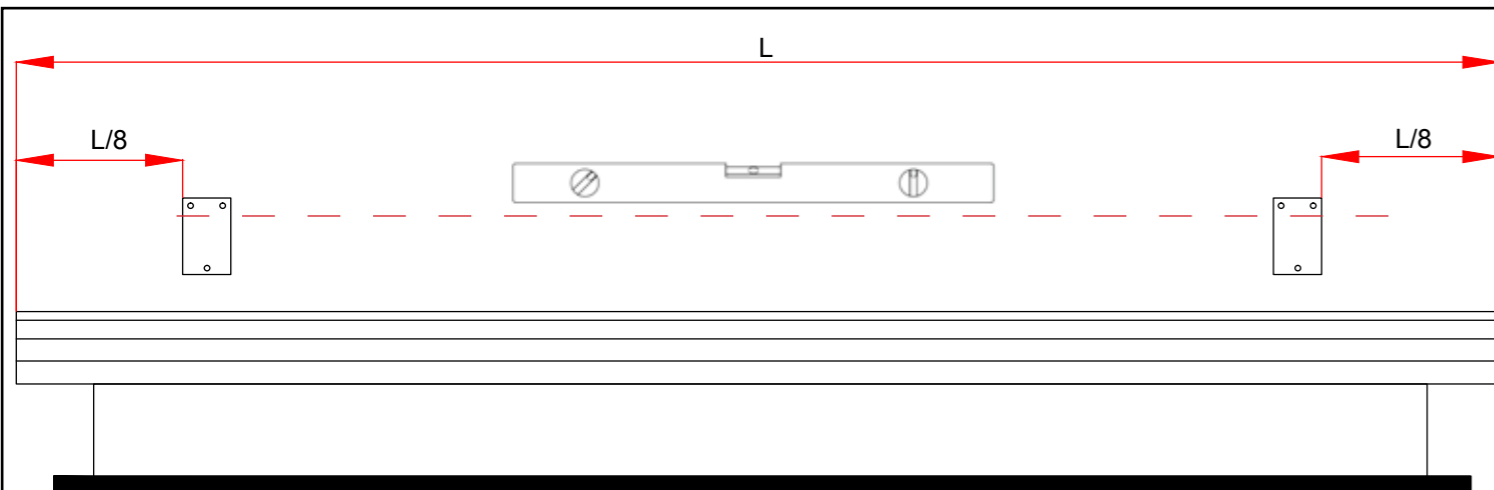

**JAGO TENSIONATO**

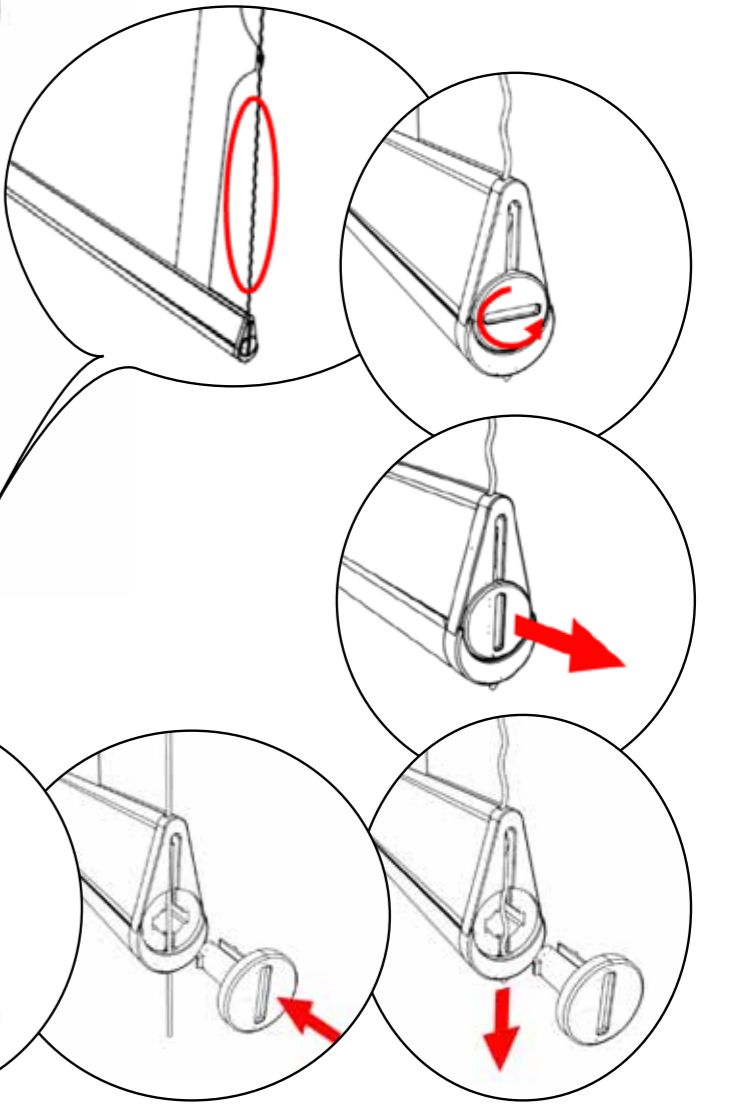
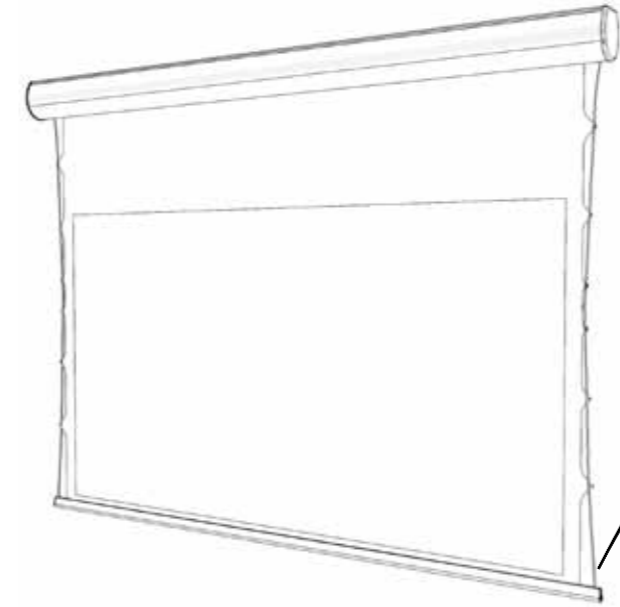

La tela in PVC è molto sensibile al calore. In un ambiente molto caldo la tela può ammorbidirsi eccessivamente ed allungarsi verso il basso alterando il rapporto video. **Si deve evitare assolutamente di posizionare lo schermo davanti a finestre illuminate dal sole oppure sopra termosifoni, caminetti e stufe di ogni genere. Maggiore sarà il calore assorbito dallo schermo, maggiore sarà la deformazione del telo che assumerà una forma allungata con i bordi laterali incurvati.**

The PVC fabric is very sensitive to heating. In a very hot environment the fabric can soften excessively and stretch down by altering the video ratio. **You should absolutely avoid placing the screen in front of sunlit windows or above radiators, fireplaces and stoves of all kinds. The higher will be the heating absorbed by the screen, the higher will be the deformation of the surface which will assume an elongated shape with curved lateral edges.**